

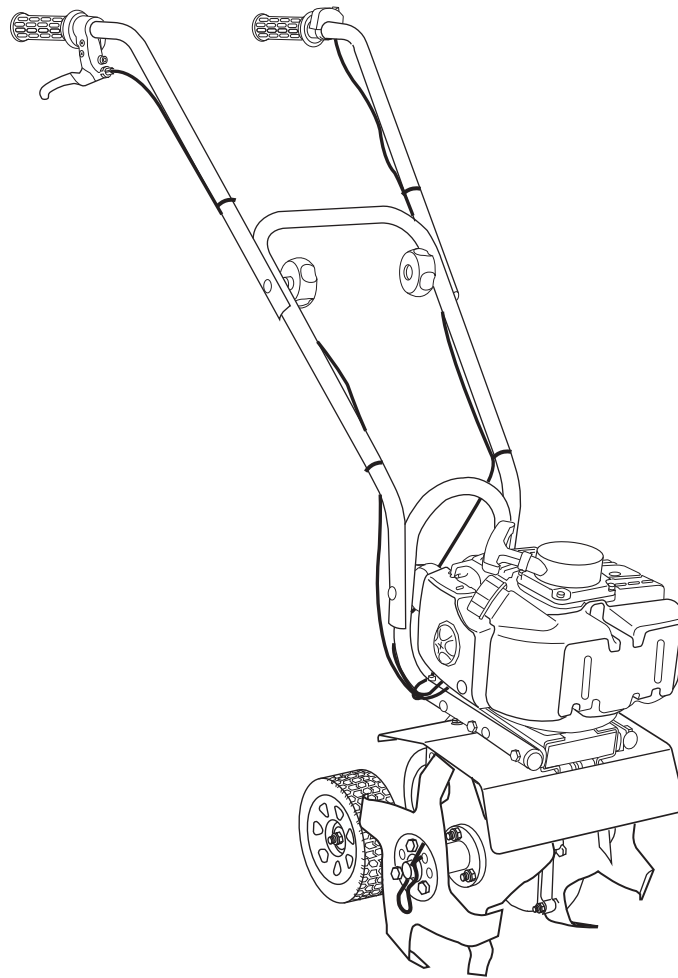

**DIRTY HAND
TOOLS**

10" Mini-Cultivator



MODEL # 103350

Operation Manual



This safety alert symbol identifies important safety messages in this manual. Failure to follow this important safety information may result in serious injury or death.

Part # 104503 Rev B

Designed & Engineered in Colorado, USA



Assembled with Foreign & Domestic Components

For Service or Questions

Call 1-877-487-8275

720-287-5182

www.dirtyhandtools.com

Dirty Hand Tools® is a brand of



FrictionlessWorld

1100 W 120th Ave, Suite 600
Westminster, CO 80234 • 720-287-5182

Table of Contents

Important Safety Information	
Intended Use	4
Personal Protective Equipment	4
General Safety	5
Safety Decals	6
Unpacking	
Adjusting the Handlebars.....	7
Overview of Components	8
Operating Precautions	9
Preparation for Operation	10
Pre-Start Inspection	10
Operating Instructions	
Filling with Oil/Gasoline Mixture	11
Adjusting the Depth Regulator	11
Starting the Engine	11
Cultivating.....	12
Drive Lever	12
Cultivating Tips	12
Maintenance	
Lubrication.....	13
Cleaning the Tine Axle Shaft.....	13
Transmission Oil	13
Engine Maintenance	13
Storage	14
Troubleshooting	15
Warranty & Specifications	Back Cover

Important Safety Information



WARNING

WARNING: Read and thoroughly understand all instructions and safety information before assembling or operating this cultivator. Failure to do so may cause serious injury or death. Do not allow anyone to operate this cultivator who has not read this manual. As with all power equipment, a cultivator can be dangerous if assembled or used improperly. Do not operate this cultivator if you have doubts or questions concerning safe operation.

Call our customer service department at **720-287-5182**, **1-877-487-8275**, or visit www.dirtyhandtools.com if you have any questions or concerns about the safe operation of this equipment.



DANGER

Intended Use

Do not use the cultivator for any purpose other than tilling garden soil for which it was designed. Any other use is unauthorized and may result in serious injury or death.

Personal Protective Equipment

When operating this cultivator it is essential that you wear safety gear including goggles or safety glasses, steel toed shoes and tight fitting gloves (no loose cuffs or draw strings). Always wear ear plugs or sound deafening headphones to protect against hearing loss when operating this cultivator. Always wear sturdy footwear. Never wear sandals, sneakers or open shoes, and never operate the cultivator with bare feet. Do not wear loose clothing that might get caught in moving parts.



CAUTION

YOUR CULTIVATOR IS EQUIPPED WITH A SAFETY CONTROL LEVER THAT ENABLES YOU TO STOP THE TINES QUICKLY IN AN EMERGENCY.

Learn how the drive safety control lever operates and how to control the cultivator at all times.

Read the entire Operation Manual before using this equipment!

Important Safety Information

General Safety

Failure to follow warnings, cautions, assembly and operation instructions in the Operation Manual may result in serious injury or death.



DANGER

READ THE OPERATION MANUAL BEFORE OPERATION.

- **Do not** permit children to operate this equipment at any time.
- **Do not** permit others that have not read and understood the complete Operation Manual to operate this equipment.
- Keep all people and pets a minimum of 10 feet away from the work area when operating this cultivator.
- **Do not** operate the cultivator when under the influence of alcohol, drugs or medication.
- **Do not** allow a person who is tired or otherwise impaired or not completely alert to operate the cultivator.



DANGER

CAREFULLY INSPECT THE AREA TO BE TILLED AND REMOVE ALL FOREIGN OBJECTS.

Do not till above underground water lines, gas lines, electric cables, or pipes. Do not operate the cultivator in soil with large rocks and foreign objects which can damage the equipment.

- Handle fuel with care; it is highly flammable. Use an approved fuel container. **Never add fuel to a running engine or hot engine.**
- Fill fuel tank outdoors with extreme care. **Never fill fuel tank indoors.**
- Replace gasoline cap securely and clean up spilled fuel before restarting.
- Never attempt to make any adjustments while the engine is running.

Important Safety Information

Safety Decals

Safety labels on the cultivator are to remind you of important information while you are operating the unit. Make sure all safety warning decals are attached and in readable condition. Replace missing or defaced decals. Contact Dirty Hand Tools at 1-877-487-8275 for replacement decals.

! DANGER

AVOID INJURY FROM ROTATING TINES!

KEEP HANDS, FEET AND CLOTHING AWAY!



Stop engine and remove spark plug wire before removing debris from tines.



! WARNING

AVOID INJURY

Read the Operator's Manual Before Operating

Wear Safety Goggles or Eyewear

Wear Boots or Protective Footwear

Wear Gloves and Protective Clothing

- Remove rocks/obstacles from tilling path.
- Check for underground utilities.

FUEL MIX: 40:1

1 GALLON GAS

3 FL. OZ. 2-CYCLE OIL

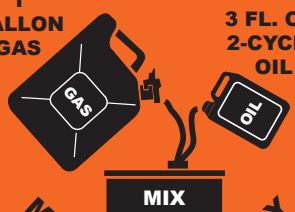

MIX THOROUGHLY

104515



DEPRESS LEVER TO ENGAGE TINES

Unpacking

Adjusting the Handlebars

Open top of carton and remove the cultivator and the upper and lower handlebars which are packed separately. Attach the lower handle bars to the handlebar support on the cultivator with two adjustment knobs. Then attach the upper to the lower handlebars with two adjustment knobs. Note that the knobs attach on the inside with carriage bolts threaded through the square holes on the outside of the handlebars (see Figure 1).

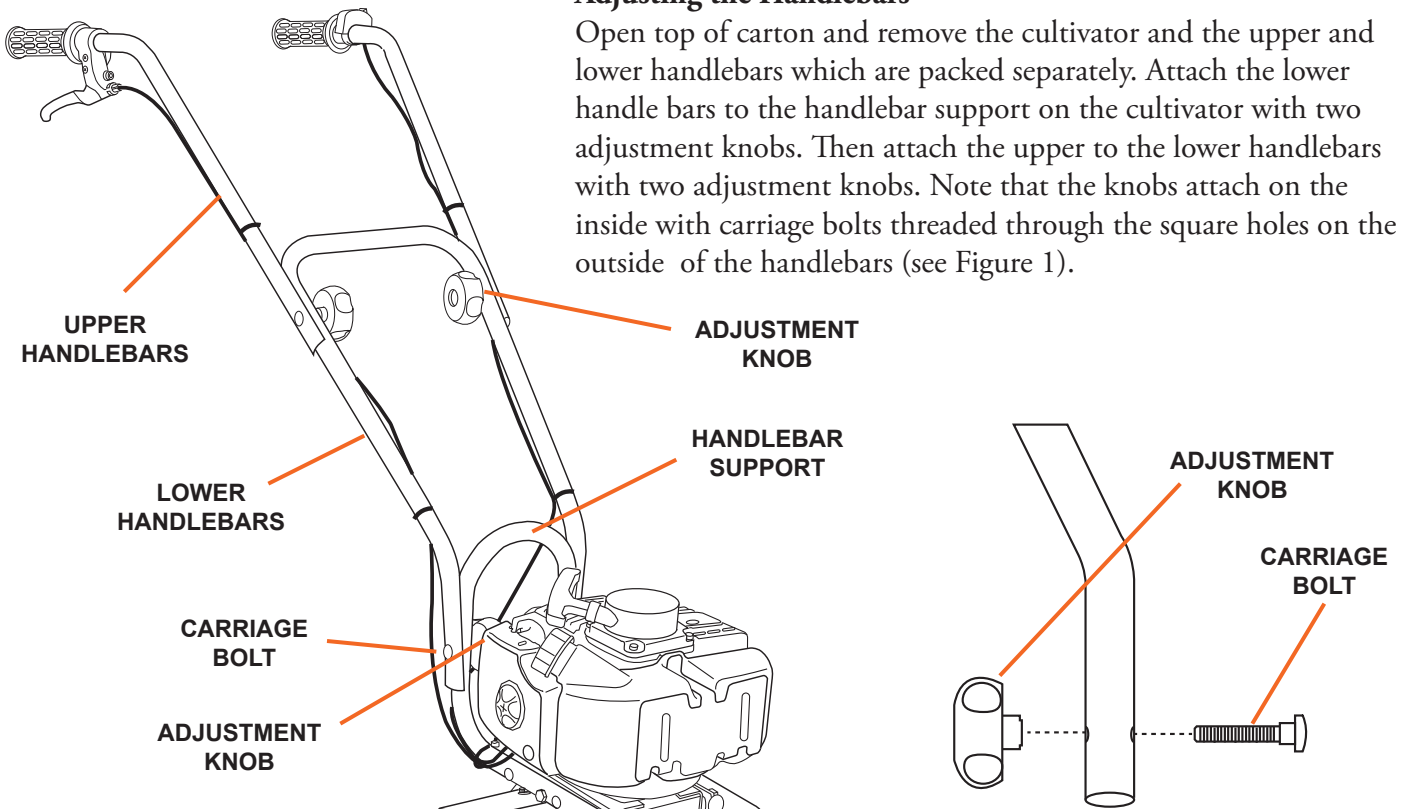

Figure 1

Wheel/Depth Regulator Assembly

Attach the wheels and depth regulator with hex bolt, spacer, washer and hex nut (see Figure 2).

Adjusting the Wheel Height

Remove the locking pin and slide the depth regulator up or down, position at desired height and reinstall the locking pin (see Figure 2).

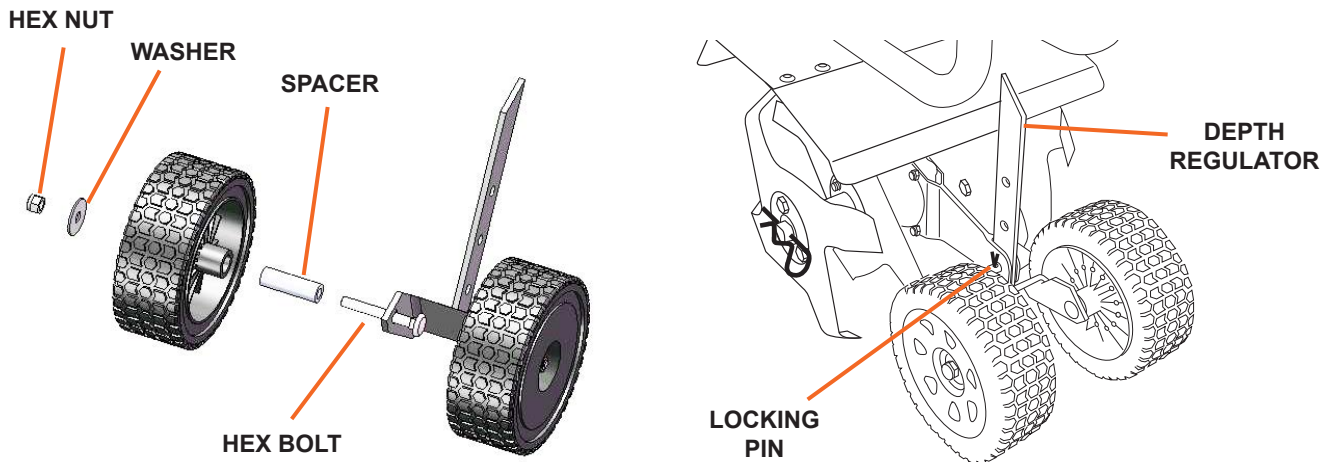
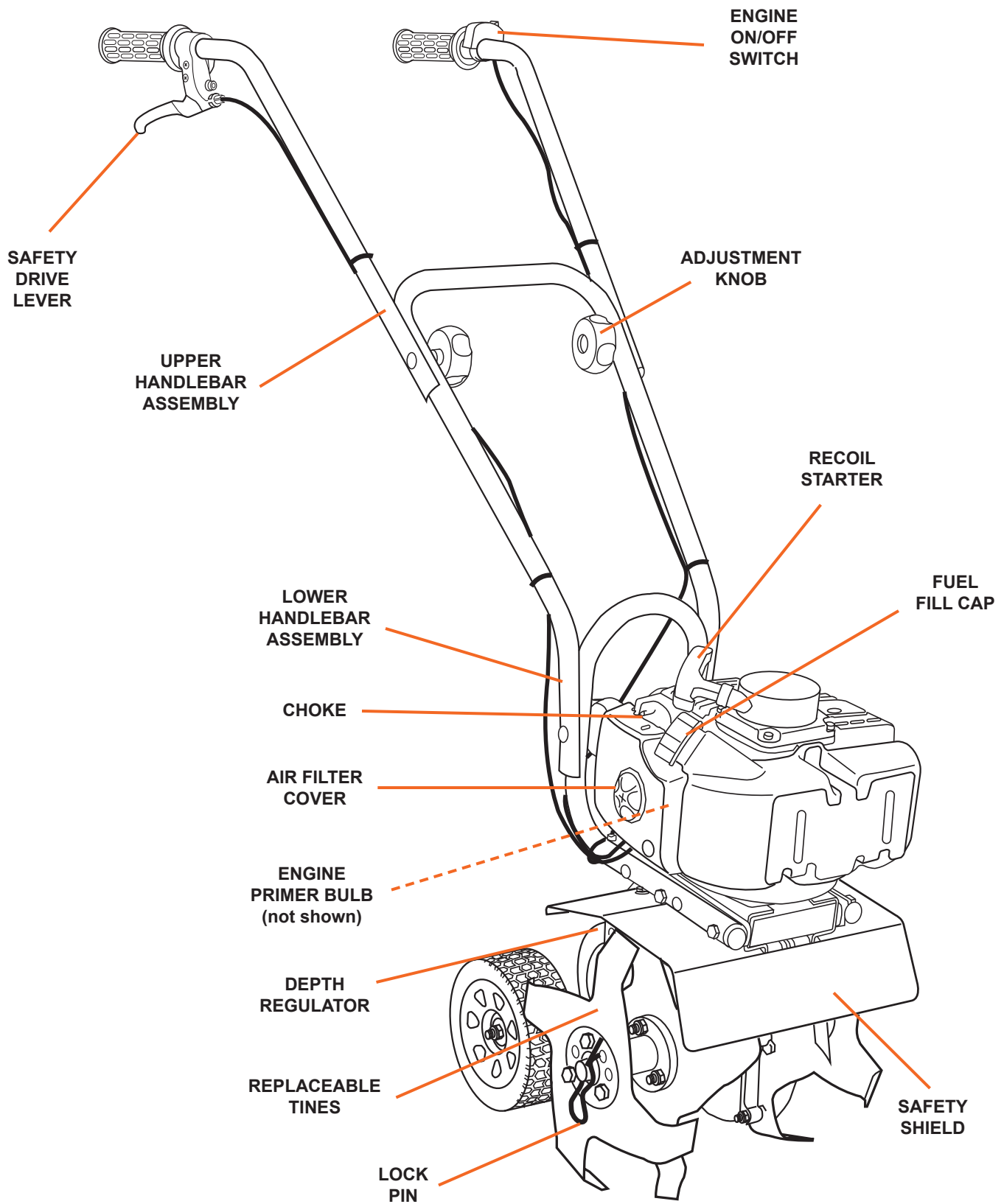

Figure 2

Overview of Components



Operating Precautions



CAUTION

READ, UNDERSTAND AND FOLLOW ALL OF THE PRECAUTIONS BELOW.

- **Never** operate the cultivator without safety shields in place.
- **Keep hands, feet, and clothing away from rotating parts. Keep clear of cultivator tines at all times.**
- Tines rotate when the engine is running and drive lever is depressed (pulled towards handlebars). *Releasing the drive lever stops the tines.*
- After striking an obstacle, **stop the engine**, remove the wire from the spark plug, inspect the cultivator for damage and repair before restarting.
- If tines become clogged, **stop the engine** and **disconnect the spark plug wire** before removing any obstruction.
- **Engine muffler will be hot** from operation. Do not touch it with bare skin or a severe burn may result.
- If the unit vibrates abnormally, stop the engine and check for the cause. *Vibration is an indication of a potential problem.*
- **Do not** run the engine indoors; exhaust fumes are deadly.
- **Do not** overload the cultivator by trying to till too deep or too fast.
- Use only attachments and accessories approved by the manufacturer.
- **Never** operate the cultivator without good visibility or good light.
- Be careful when tilling in hard ground. The tines may catch in the ground and propel the cultivator backwards. *If this occurs, let go of the handlebars and do not restrain the machine.*
- **OPERATING THE CULTIVATOR FOR LONGER THAN ONE MINUTE AT HIGH SPEED WITH TINES REMOVED FROM THE GROUND WILL DAMAGE THE ENGINE.**
- **Take precautions when leaving the machine unattended.**
Disengage all control levers, stop the engine, wait for all moving parts to stop, and make certain guards and shields are in place.
- **Shut off the engine when leaving the operating position** for any reason. Wait for all moving parts to stop.



WARNING

OPERATION OF ANY CULTIVATOR CAN RESULT IN FOREIGN OBJECTS BEING THROWN. ALWAYS WEAR SAFETY GLASSES DURING OPERATION.

Preparation for Operation

Pre-Start Inspection

1. Make sure safety shields are in place and nuts & bolts are secure.
2. Check fuel supply. Fill the fuel tank no closer than 1 inch from top of tank to provide space for expansion.
3. Inspect air filter. Clean or replace as needed.
4. Be sure spark plug wire is attached and is tightened securely.
5. Examine underneath and around engine for oil or fuel leaks.
6. Inspect fuel hoses for tightness and fuel seepage.
7. Look for signs of engine damage.
8. Remove excessive debris from muffler area and recoil starter.

Filling with Oil and Gasoline Mixture



WARNING

Mix unleaded gasoline with 2-cycle engine oil at a ratio of 40:1 in a separate container and add to the fuel tank before starting the engine.

1. Place the cultivator on a level surface outdoors in a well-ventilated, dry area, away from building air intakes.
2. Mix one gallon of 87+ octane gasoline with 3 fl. oz. of two-stroke engine oil in an approved container. Slowly shake the container to thoroughly mix the gasoline/2-cycle oil.



WARNING

Do not run the engine with an improper gasoline/2-cycle oil mixture. Running the engine with an improper mixture WILL permanently damage the engine and void the warranty.

- Always fill the tank with the engine off and cool.
- Always check the fuel level before operation.
- Allow the engine to cool for at least two minutes before removing the fuel cap.
- Do not fill with fuel indoors or near any source of combustion.
- Do not smoke when fueling or operating the cultivator.
- Do not overfill with fuel.

Checking Transmission Oil

The transmission oil is filled at the factory. Should it require filling use SAE30 engine oil and fill to top of the reservoir (see Figure 3).

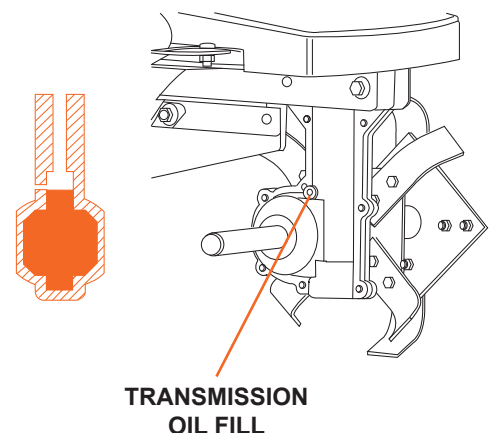
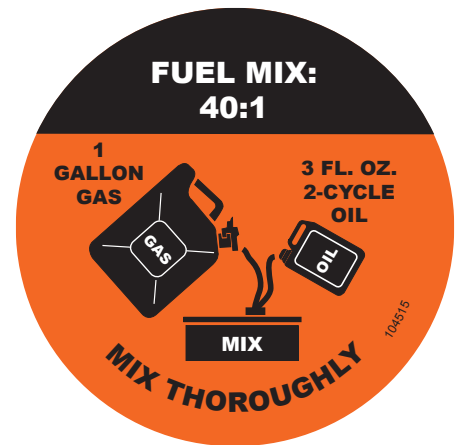

Figure 3

Operating Instructions

Adjusting the Depth Regulator

Remove the locking pin and reverse the depth regulator and wheels, slide up or down to position at desired tilling depth and reinstall the locking pin (see Figure 4).

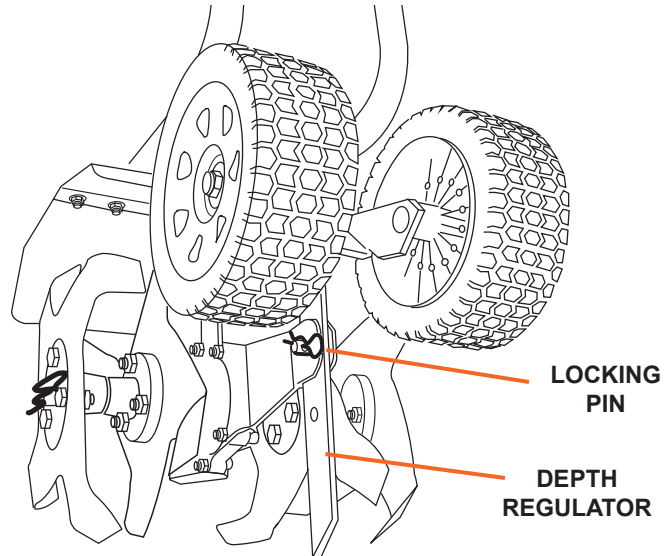

Figure 4

Starting the Engine

Make sure that the cultivator is on a level, stable position before starting the engine. Do not start the engine if there is spilled fuel.

1. Turn the engine's ON/OFF switch to ON (see Figure 5).
2. Pump the engine primer bulb until it fills with fuel.
3. Turn the engine's choke lever to the CLOSED position. Set the choke lever to the OPEN position only when the engine has started or upon restarting a warm engine.
4. Pull the recoil starter handle slowly until you meet some resistance. Pull the recoil starter with a rapid full arm stroke allowing the starter rope to rewind slowly. Repeat as necessary until the engine starts running.
5. After the engine warms up and starts running normally, move the choke lever to the OPEN position.

Note: Allow the engine to warm up for 30 seconds before moving the choke lever to the OPEN position.

5. The first 25 hours of operation is the break-in period. Breaking-in the Engine will help ensure proper equipment and engine operation, and will extend the engine's lifespan. After the first 25 hours of use change the gasoline/2-cycle oil fuel mixture.

Pulling the safety drive lever towards the handlebar engages the tines.

On/Off Switch

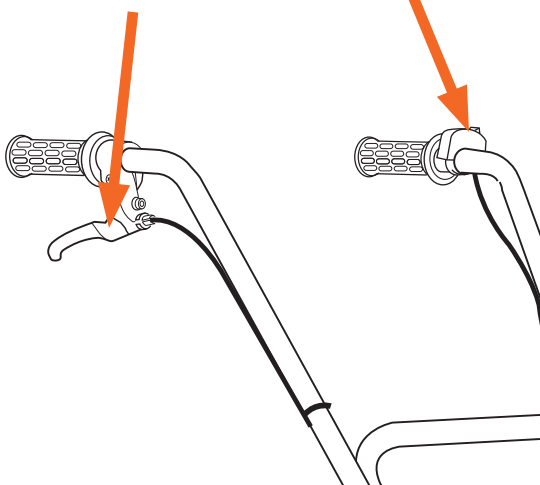

Figure 5

Operating Instructions



WARNING

PRACTICE OPERATING THE CONTROLS AND USING THE CULTIVATOR WITH TINES OUT OF GROUND BEFORE BEGINNING TO TILL.

It is important that you know how to use the cultivator properly, keep control at all times, stop the tines and wheels from turning, and stop the engine if necessary.

Read the entire Operation Manual before using the equipment!

Cultivating

Start the cultivator (rotating the tines) by pulling up on the drive lever - this will engage the tines.

Drive Lever

Pulling the drive lever toward the handlebar engages the tines.

Releasing the lever stops the tines.

Note: You can slow the cultivator's forward advance at any time by putting slight downward pressure on the handlebars. Stop the cultivator by releasing the drive lever and then stop the engine.

Cultivating Tips

The key to successful cultivating is to begin with a shallow cut on the first pass, and then work an inch or two deeper on each successive pass.

- Tilling depth will vary with ground conditions.
- When beginning to till in unbroken ground or in extremely hard soil perform shallow tilling first then do a second pass going deeper into the soil.
- Hold on firmly to the handlebars to control sudden lurches.

Immediately release the drive control lever if the tines jam or you strike a foreign object. With the drive lever released, push the throttle control to the stop position to stop the engine. Disengage the spark plug wire. When tines have stopped, remove foreign objects and check for damage.

Maintenance



- Keep cultivator, safety shields and covers, attachments, and accessories in safe working condition.
- Check locking pins, engine mounting bolts, and other bolts at frequent intervals for proper tightness.
- To prevent accidental starting, always disconnect and secure the spark plug wire from the spark plug before maintenance.
- Never run the engine indoors. Exhaust fumes are toxic.
- Always allow muffler to cool before filling fuel tank.

Lubrication

Proper lubrication of moving mechanical parts is critical for proper care and maintenance. Oil the cables and other moving parts at 10 hour intervals using a SAE30 engine oil.

Checking Transmission Oil

The transmission oil is filled at the factory. Should it require filling use SAE30 engine oil and fill to top of the reservoir (see Figure 3).

Maintaining the Air Filters

1. Check and clean the air filters on a regular basis. A dirty filter will effect the cultivator's performance (see Figure 6).
2. Remove dust from both filters. Any residue can be cleaned with a small amount of gasoline. Add a small amount of oil to the outer filter, squeeze to remove any excess and reinstall.

Cleaning the Tine Axle Shaft

1. Turn off engine. Engine must be cool.
2. Remove spark plug wire and secure from spark plug.
3. Tip the cultivator backward. Block the cultivator in position so that the tines are exposed.
4. Remove all vegetation, string, wire, and other material that may have accumulated on the axle between the inside set of tines.

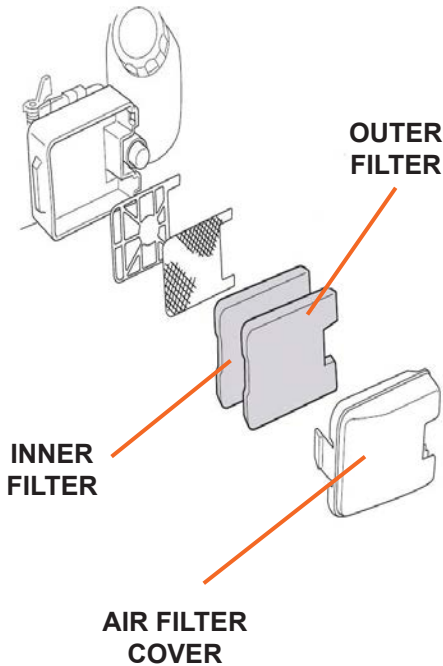

Figure 6



WARNING

Detach spark plug wire and allow engine to cool down!

Engine Maintenance

Refer to the engine manual included in your parts packet for information on engine maintenance.

1. Check oil level before each use and after 8 hours of operation.
2. Change oil after first 5-8 hours of operation.
3. Check spark plug yearly or every 100 hours of operation.
4. Service air cleaner.
5. Keep engine and parts clean.
6. Check engine and equipment often for loose nuts and bolts.



WARNING

DO NOT STORE THE CULTIVATOR IN UNVENTILATED AREA

where fuel fumes may reach flame, sparks, pilot lights or other ignition source.

Drain fuel outdoors away from any ignition sources.

Use only approved fuel containers.

Never store equipment with gasoline in the tank inside of a closed building where fumes may reach an open flame or spark. Allow the engine to cool before storing in any building.

Add a fuel stabilizer to gas tank and run for 10-15 minutes to prevent fuel from gumming up during an extended storage period.

Prepare for Storage

Follow the steps below to prepare your cultivator for storage. Read your engine manual for detailed instructions on preparing the engine for storage.

1. Protect wheels and axles from rust: Remove lock pin and slide wheel off hub. Coat the axles lightly with axle grease. Slide wheel back on hub and insert lock pin.
2. Drain fuel system completely following engine manufacturer's instructions or add fuel stabilizer to prevent fuel from gumming up during extended storage period.
3. While engine is still warm, drain the oil from the engine. Refill with fresh oil of the recommended grade.
4. Clean external surfaces, engine and cooling fan.
5. Remove spark plug, pour one ounce of SAE 30 oil into spark plug hole.
6. Plug hole and pull starter cord slowly to distribute oil evenly in cylinder head area.
7. Reinstall spark plug.
8. Transport unit to a suitable storage location. If you have chosen to use a fuel stabilizer and have not drained the fuel system, follow all safety instructions storage precautions in this manual to prevent the possibility of fire from the ignition of gasoline fumes. Remember, gasoline fumes can travel to distant sources of ignition and ignite, causing risk of explosion and fire.
9. If there is any possibility of unauthorized use or tampering, remove the spark plug and store it in a safe place before storing the cultivator unit. Be sure to plug the spark plug hole to prevent foreign material from entering.

Troubleshooting

PROBLEM	SOLUTION
Engine will not start	<ul style="list-style-type: none"> • Add fuel to fuel tank. • Connect spark plug wire to spark plug • Choke should be at start position for a cold start
Engine runs rough, floods during operation	<ul style="list-style-type: none"> • Clean or replace air cleaner
Engine is hard to start	<ul style="list-style-type: none"> • Drain old fuel and replace with fresh. Make sure the 2-cycle oil to gas mixture is correct. • Make sure spark plug wire is securely attached to spark plug • Drive safety control levers must be released to neutral position to start the engine • Choke is not in proper start position
Engine misses or lacks power	<ul style="list-style-type: none"> • Raise the tines for shallow tilling by lowering the depth regulator lever • Remove and clean fuel tank • Clean or replace air cleaner • Improper carburetor adjustment, take to authorized engine service center • Replace spark plug and adjust gap • Drain and refill gas tank and carburetor
Engine will not stop when throttle control is positioned at stop	<ul style="list-style-type: none"> • See engine manual to check and adjust the throttle linkage
Cultivator is difficult to control when tilling (machine jumps or lurches forward)	<ul style="list-style-type: none"> • Push downward on the handlebars raising the tines • Keep the tines raised slightly for shallower tilling on hard soils, then do a second pass going deeper • Raise the cultivator depth regulator
Tines do not rotate with Driver Safety Control Lever depressed	<ul style="list-style-type: none"> • Drive cable is damaged or incorrectly adjusted • Drive belt is damaged
Tines continue to rotate after the Driver Safety Control Lever is released	<ul style="list-style-type: none"> • Drive cable is damaged or incorrectly adjusted
Excessive heat build up in tine area during tilling	<ul style="list-style-type: none"> • Clean the tine axle shaft • Check transmission fluid and fill if low

Warranty & Specifications

IMPORTANT NOTICE

We, the manufacturer, reserve the right to change the product and/or specifications in this manual without notification. The manual is for information usage only and the pictures and drawings depicted herein are for reference only.

Warranty Repair and Service

Do not return this product to the store for warranty issues or repair. Call our customer service department at **720-287-5182**, **1-877-487-8275**, or visit www.dirtyhandtools.com for the location of the nearest service center.

Record the information below for future reference.

Model No. _____

Serial No. _____

Date of Purchase _____

Place of Purchase _____

Specifications

SKU/Part No.	103350
Description	10 Inch Front Tine Cultivator
Engine	43cc Engine*, Single cylinder, two-stroke, air cooled, EPA Approved
Fuel Tank Capacity**	34 ounces
Fuel Mix	40:1 unleaded gasoline to 2-stroke engine oil
Operating Speed	7000-8500 RPM
Tilling Width	10"
Tilling Depth	5"
Tires	5" diameter
Transmission	Neutral (disengaged), and Forward (engaged)
Dimensions	43"L x 22"W x 37"H (including handlebar)
Shipping Weight	40 Lbs.
Warranty	2 Year / 2 Year Limited Warranty

*As rated by engine manufacturer

Dirty Hand Tools® is a brand of
 **FrictionlessWorld**
1100 W 120th Ave., Suite 600
Westminster, CO 80234 • 720-287-5182

For Service or Questions
Call 1-877-487-8275
720-287-5182
www.dirtyhandtools.com